

BARONESS
Quality on Demand

Bunker rake

SP05

[Front Blade]

Assembly and Installation manual

Serial No.#10001~

Thank you for purchasing this Baroness product.

This manual describes how to handle this product and make adjustments.

Please be sure to carefully read and fully understand the owner's manual and this manual before use.

This machine was shipped after a thorough inspection. However, the performance of the machine is greatly affected by handling and daily maintenance, such as inspection and adjustments before and after operation. Please handle this machine properly and perform necessary inspection and adjustments before and after operation in order for the product to fulfill its original function and ensure safe operation.

For operation and inspection, refer to the owner's manual. For necessary parts, refer to the parts catalogue.

Trädgårdsteknik AB

Caution

The information described in this manual is subject to change without prior notice for improvement. When replacing parts, be sure to use genuine Baroness parts or parts designated by Trädgårdsteknik AB. Note that the Baroness product warranty may not apply to defects caused by the use of parts from other companies.



This symbol is accompanied by the word "Danger," "Warning," or "Caution." All labels with this symbol describe important safety precautions, so please read such labels carefully and only operate the machine after you have understood them completely. Failure to adequately follow these safety precautions may cause an accident.

Danger:

This symbol indicates that serious injury or death will occur if the warning is ignored.

Warning:

This symbol indicates that serious injury or death may occur if the warning is ignored.

Caution:

This symbol indicates that injury or damage to property may occur if the warning is ignored.

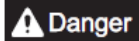

When installing, removing, and adjusting optional equipment and attachments, observe the following safety instructions to ensure safe operation.

1. Before installation, removal, adjustments, etc., park the machine on a level surface. Set the parking brake, stop the engine, and remove the key. Ensure that all the parts have come to a complete stop.
2. Keep your hands and feet away from moving parts. Avoid performing work with the engine running. Keep other people away from the machine during work.
3. If necessary, use appropriate chain blocks, hoists, or a jack. If the machine is lifted up, ensure that it is supported by jack stands or appropriate blocks.
4. When replacing parts or installing accessory parts, use genuine BARONESS parts.
5. Never start the engine in a closed room. Doing so could cause carbon monoxide poisoning.

Installing Optional Equipment for the SP05









Front Blade

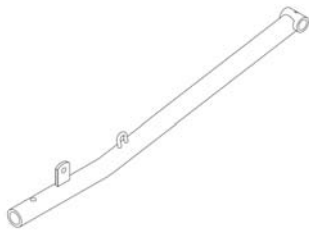

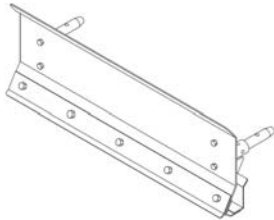

Intended use: The front blade section is used to restore the sand that has been lost due to heavy rain, etc.

This can be finely and easily adjusted by hand. Operating width: 80 cm (31 in.)

Check that all parts are included. The following parts are included in the package.

Should any part be missing or damaged, please contact the dealer you purchased it from.

Front blade Ass'y SP160EA0820Z0					
1	Front blade Arm SP160EA0810ZD Qty:2	2	3.2SPHC Metal Washer 1035 K5073210352 Qty 2	3	10S Washer K0200100002 Qty:7
					
4	10 Bolt 20 K0000100202 Qty:2	5	Front blade Lever Qty:1	6	Front blade Qty:1
					
7	Delta Pin9 K0450000028 Qty:2	8	Arm Backing Plate COMP Qty:1	9	10 Washer K5000100002 Qty:1
					

10	10 Bolt 25 K0000100252 Qty:1	11	Connecting shaft Qty:2	12	10 Nut K0100100002 Qty:4
					
13	2.9 Round Spring Hook 3895 K103000026D Qty:2				
					

Tightening torque

Required tightening torque	Nominal diameter	Appropriate tightening torque [General bolts Strength class: 4.8]		
		N-m	kgf-cm	lb-in
-	M6	7-9	71.38~91.77	61.96~79.66
-	M8	14-19	142.76~193.74	123.91~168.17
○	M10	29-38	295.71~387.49	256.68~336.34

Caution

When tightening bolts, refer to the above table. We will not be held responsible for any damage resulting from improper or excessive tightening, etc.

SP05

Installing the Front Blade Section

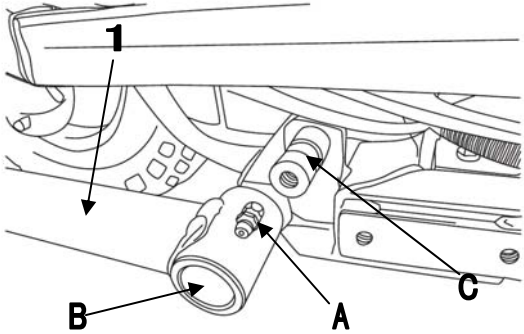
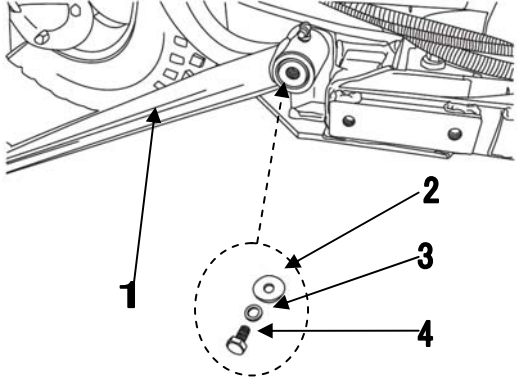
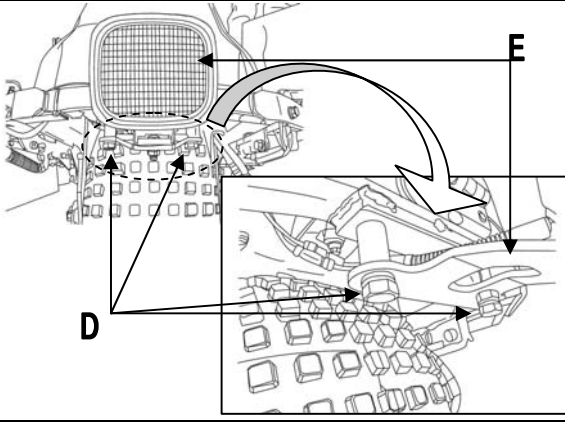
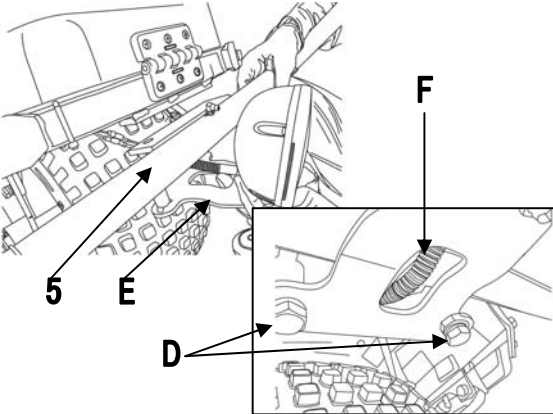
Steps	Illustrations	Descriptions
1		<p>Apply grease to part B and parts C of the left and right frames and install the front blade arms (1) in the correct direction (grease nipple A).</p>
2		<p>After installing the front blade arm (1), secure it with the washer (2), S washer (3), and bolt (4).</p>
3		<p>Firmly support the light ass'y (E) and remove the light mounting bolts (D).</p>
4		<p>Secure the front blade lever (5), the light ass'y (E), and the light mounting bolts (D) again in this order. *When securing them, pass the light cable (F) through the elongated hole on the frame so that the cable is not caught in the frame.</p>

SP05

Installing the Front Blade Section

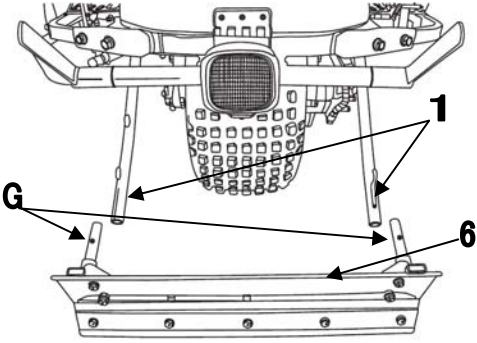
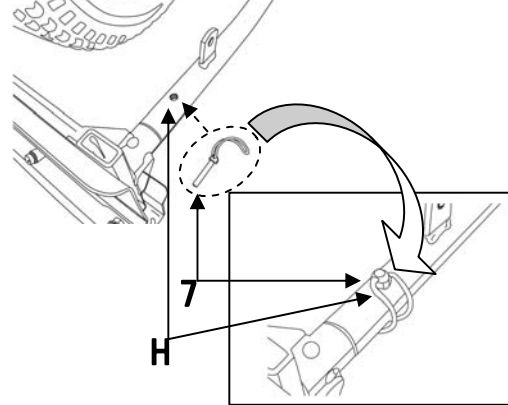
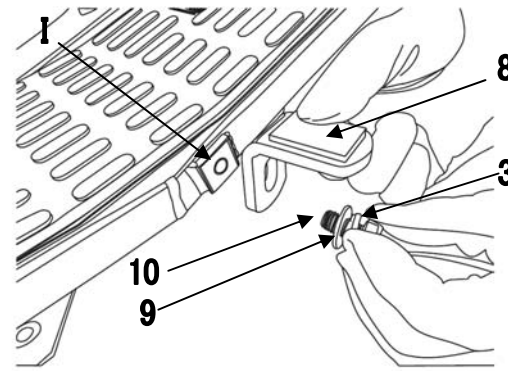
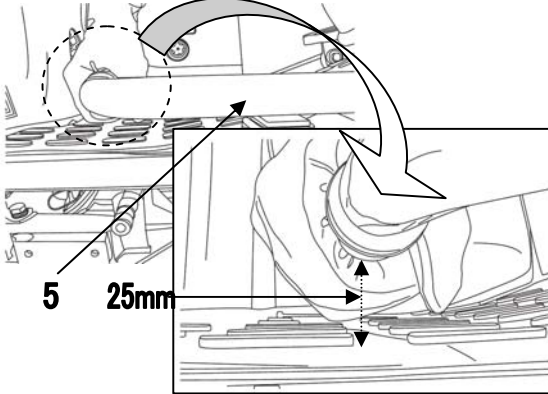
Steps	Illustrations	Descriptions
5		<p>Apply grease to part G of the front blade (6) and install the front blade ass'y to the front blade arms (1).</p>
6		<p>Install the delta pin (7) to part H on both sides.</p>
7		<p>Install the arm backing plate COMP (8) to part I located at the right side of the frame (the right side of the machine) with the washer (9), S washer (3), and bolt (10).</p>
8		<p>Adjust the arm backing plate COMP (8) so that the distance between the grip of the front blade lever (5) and the upper surface of the step sheet is about 25 mm (1 in.) and secure it with the bolt (10). Adjust the arm backing plate COMP (8) so that there is a little clearance when the grip is held and so that the grip is easy to hold.</p>

SP05

Installing the Front Blade Section

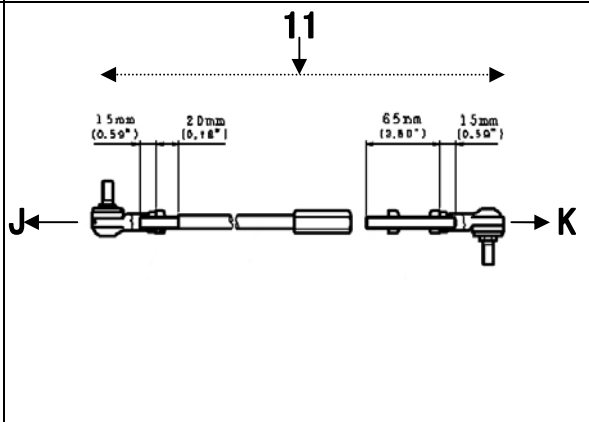
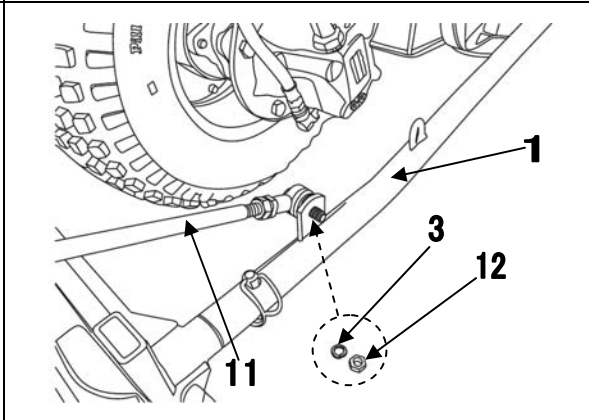
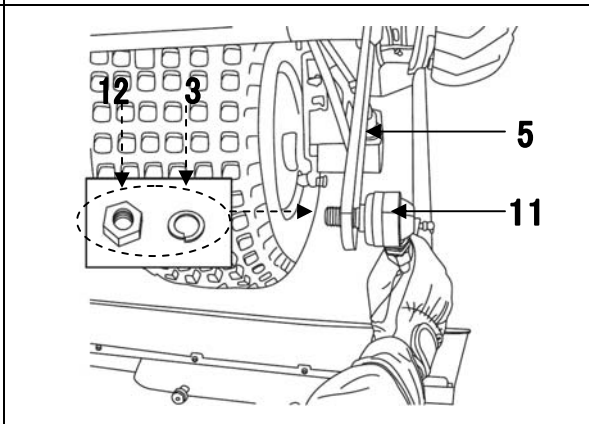
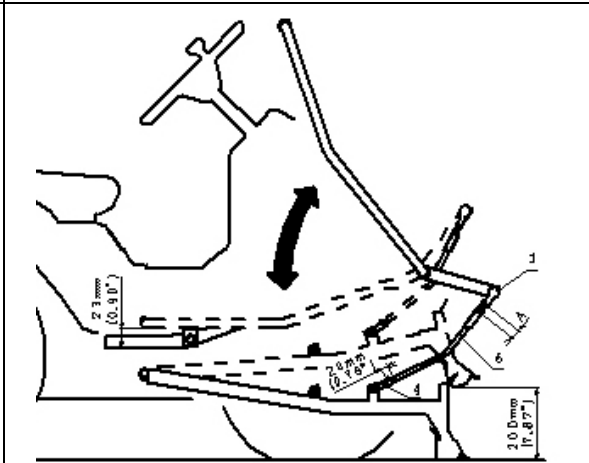
Steps	Illustrations	Descriptions
9	 <p>11</p> <p>15 mm (0.59") 20 mm (0.78") 65 mm (2.56") 15 mm (0.59")</p> <p>J K</p>	<p>The connecting shaft (11) is set as shown in the illustration when the machine is shipped.</p> <p>Be careful to install the connecting shaft (11) in the correct direction. One end points towards J (the front blade arm (1)) and the other end points towards K (the upper part of the front blade lever (5)).</p>
10	 <p>11 1 3 12</p>	<p>Mount the connecting shaft (11) to the front blade arm (1) with the S washer (3) and nut (12).</p> <p>*Be careful to install the connecting shaft (11) in the correct direction.</p>
11	 <p>12 3 5 11</p>	<p>Mount the connecting shaft (11) to the upper part of the front blade lever (5) with the S washer (3) and nut (12). (Temporarily tighten the washer and nut as the front blade needs to be adjusted later.)</p> <p>*Be careful to install the connecting shaft (11) in the correct direction.</p>
12	 <p>200 mm (7.87") 200 mm (7.87")</p>	<p>Adjust the connecting shaft (11) so that the position of the front blade lever is maintained and the distance between the bottom of the front blade section and the ground is about 200 mm (8 in.) when the front blade section is fully raised.</p> <p>Adjust the connecting shaft (11) so that the left and right sides of the front blade move synchronously when the front blade section is fully lowered on a level surface.</p>

SP05

Installing the Front Blade Section

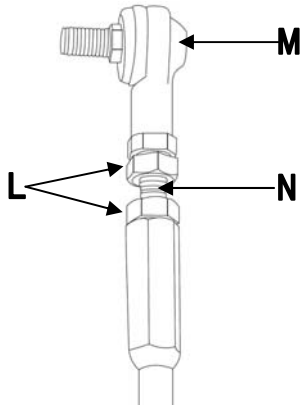
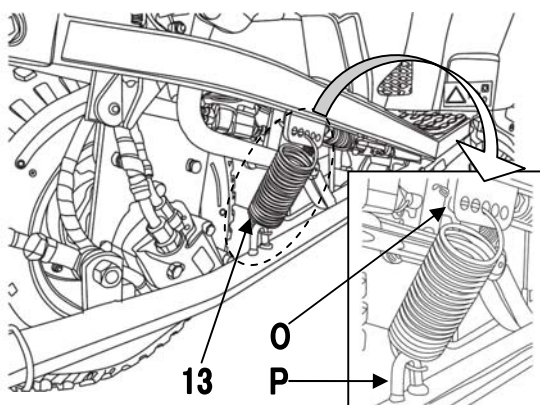
Steps	Illustrations	Descriptions
13	 A technical drawing of a connecting shaft assembly. It shows a central shaft with a ball joint at the top and a threaded section at the bottom. Label 'M' points to the ball joint, 'L' points to the upper nut, and 'N' points to the lower nut.	<p>Remove the S washer (3) and nut (12), loosen the nut (L), and rotate the L-ball (M) and screw shaft (N) to the left and right to adjust the length of the connecting shaft (11).</p> <p>After adjusting the front blade section, install and fully tighten the S washer (3) and nut (12).</p>
14	 A technical drawing showing the front blade section being installed into the machine frame. A spring hook (13) is being inserted into a hole in the frame (O) and attached to a part of the front blade arm (P). The drawing includes a callout showing a close-up of the spring hook and the frame hole.	<p>Insert the spring hook (13) into the frame (O) (the middle hole of the five holes) and part P of the front blade arms. This completes the installation.</p> <p>*The spring tension can be adjusted by inserting the spring hook into a different hole. Adjust the spring hook to the desired tension.</p>

Removing the Front Blade Section (See the illustrations for installing the front blade section.)

1. Remove the spring hook (13) from the frame (O) and part P of the front blade arms.
2. Remove the connecting shaft (11) from the upper part of the front blade lever (5) and front blade arms (1).
3. Remove the delta pin (7) and then remove the front (6) from the front blade arms (1).
4. Remove the washer (2), S washer (3), and bolt (4), and then remove the front blade arms (1).
5. Remove the light mounting bolt (D) and then remove the front blade lever (5).
6. Re-mount the light ass'y (E) with the light mounting bolt (D).
7. Remove the washer (9), S washer (3), and bolt (10) from the right side of the frame (the right side of the machine), and then remove the arm backing plate COMP (8).

BEVATTNINGSTEKNIK
Helsingborgsvägen 578, Varalöv
262 96 ÄNGELHOLM, SWEDEN

Telefon: +46 431 22250
Email : info@bevattningsteknik.se eller philip@bevattningsteknik.se
www.bevattningsteknik.se